



DH07 Shown

Model # DH07, (Two Well), DH08, (Three Well) Convected Air Dish Heaters

Aladdin Temp-Rite convected air dish heaters are available in two well and three well models. These units are designed specifically for use with a wide variety of 9" (22.9 cm) china and Alacite® dishware only. (Not to be used for heating stainless steel pellet bases.)

STANDARD FEATURES:

- Durable and attractive stainless steel cabinet
- Quick and efficient convected air heating system
- Fully insulated heater compartment
- Individual field adjustable, self-leveling stainless steel mechanisms, easily removable for cleaning
- Four swivel 5" casters, two with brakes, for ease of maneuverability and stability
- Designed to heat china or Alacite
- Convenient push/pull handle
- Corner bumpers
- Lighted power switch to indicate operational mode
- Tight fitting lid design seals without gasket
- Removable service panel for easy access to temperature controls
- All thermostatic devices are engineered for accurate, trouble-free operation
- Eight foot long, three wire, grounded electrical supply cord and plug with strain relief
- UL listed and certified to meet Canadian Standards Association and NSF Standards

SPECIFICATIONS:

HEATING SYSTEM

A forced air convection system circulates thermostatically controlled heated air evenly throughout the insulated heat compartment. The fan motor is located outside the heated compartment. The heating element is circular shaped and located around the perimeter of the fan. A resettable high limit switch (located behind access panel) is provided for added safety.

CABINET

The cabinet exterior, top, lid and dispensing mechanism is constructed of heavy gauge stainless steel with reinforcing at all stress areas. The heater compartment is separated from the cabinet exterior and is fully insulated.

TEMPERATURE MODES

Temperature is factory set for optimum heating of china and Alacite dishware.



Model # DH07, DH08 Convected Air Dish Heaters

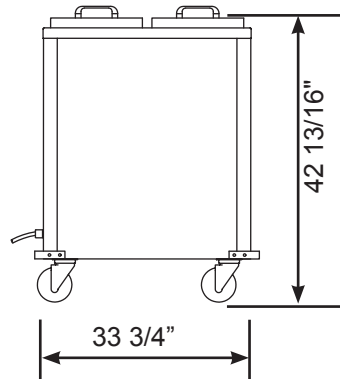
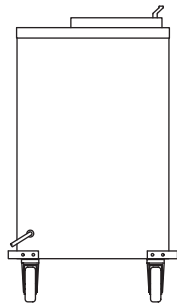
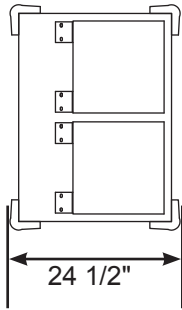

DH07 Shown

OTHER SPECIFICATIONS:

GUIDE ROD ASSEMBLY

The guide rod assembly platform shall be constructed of 12 gauge galvanized metal. Vertical rods shall be 1/2" (1.27 cm) round stainless steel rods held in place by support brackets and a collar bushing assembly. Handles to assist removal of elevating mechanism shall be heavy gauge stainless steel.

| Model Number | | DH07 | DH08 |
|-----------------|--------------------|---------------------|---------------------|
| Dimensions | Length | 33 3/4" | 47 1/8" |
| | Width | 24 1/2" | 24 1/2" |
| | Height | 42 13/16" | 42 13/16" |
| | Shipping Weight | 270 lbs | 300 lbs |
| Electrical Data | Amperage & Voltage | 15.9 Amps, 208/240V | 15.9 Amps, 208/240V |
| | Plug* NEMA 6-20P | 60HZ, Single Phase | |



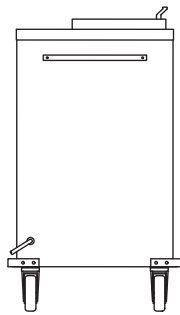
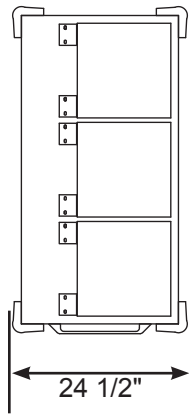

DH08 Shown

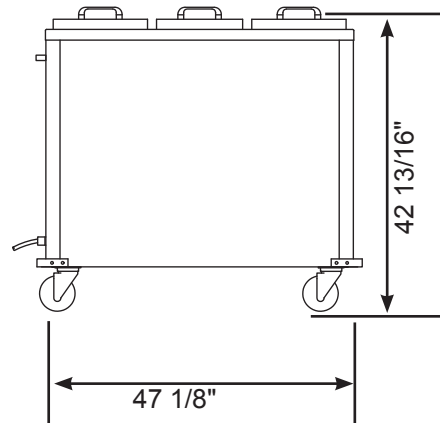

| Description | Plate Model Number | DH07 | | | DH08 | | |
|-------------------|------------------------------|-----------|---------------|-------|-----------|---------------|-------|
| | | Per Stack | No. of Stacks | Total | Per Stack | No. of Stacks | Total |
| 9" Round, China | J300, J301, J361, J461, J561 | 60 | 2 | 120 | 60 | 3 | 180 |
| 9" Round, Alacite | K95, K97, K98, K401 | 60 | 2 | 120 | 60 | 3 | 180 |