

ALADDIN TEMP-RITE® SALES CODE:
J715 — ONE 21 1/4" X 21 1/4" OPENING
J715A — ONE 21 1/4" X 21 1/4" OPENING
ONE 21 1/4" X 10 3/16" OPENING
J715B — TWO 21 1/4" X 21 1/4" OPENINGS

Aladdin Temp-Rite's® self-leveling refrigerated dispensers always keep cartoned milk, juices and beverages at a convenient serving level. You can select from three (3) models to suit your menu requirements: 55" (J715), 64" (J715A) or 79" (J715B).

STANDARD FEATURES:

- Self-leveling for efficient serving
- All stainless steel exterior finish
- Removable stainless steel insulated hinged lid covers with high impact molded plastic throat liners
- High density foamed-in-place polyurethane insulation
- Stainless steel inner tank liner
- 1" drain with valve for easy cleaning
- Finned tube forced air coils with accessible thermostat and hermetically sealed condensing unit
- R22 Refrigerant
- Maintains temperatures between 34° and 38° F
- Easily visible temperature indicator on front of unit
- Removable self-leveling mechanism for easy cleaning
- 5" swivel heavy-duty non-marking casters with brakes
- Push/pull handle for easy maneuverability
- 10' cord and plug (NEMA 5-15P)
- Edges of top to have #7 Hi-Lite finish
- Equipment supplied is UL safety and sanitation listed
- 4 non-marking corner bumpers

OPTIONS:

NOTE: Overshelf options are shown in light gray on product illustration

- One or two tier stainless steel overshelves
- Vinyl color options available
- Lid locking security device
- Full perimeter wraparound bumpers

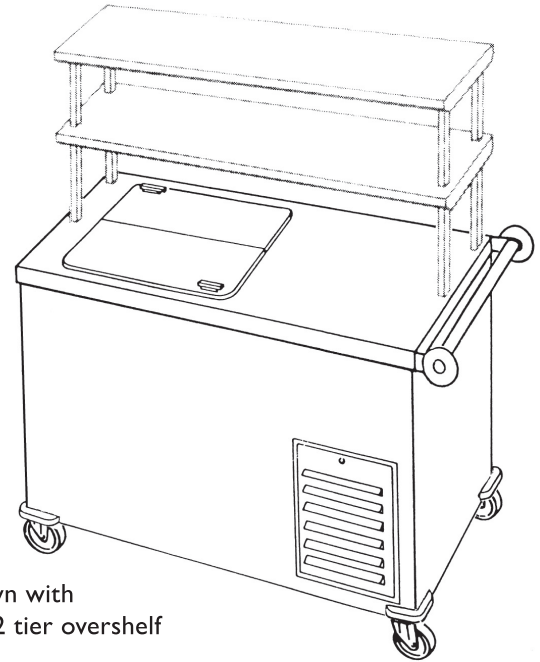

J715 shown with optional 2 tier overshelf

Refrigerated Milk/Beverage Carton Dispensers

Aladdin Temp-Rite® Sales Codes	J715	J715A	J715B
Number of openings:	1 large	1 large/ 1 small	2 large
Approximate capacities:			
2W" x 2W" x 4W" cartons (Q pints)	405	621	810
2T" x 2T" x 3" cartons (Q pints)	343	490	686
Number of 20" x 20" divider platforms	5	5	10
Number of 10" x 20" divider platforms		5	
Overall Dimensions:			
Length	55"	64"	79"
Width	32"	32"	32"
Counter Height:	37"	37"	37"
Height with optional 1 tier	51W"	51W"	51W"
Height with optional 2 tiers	64"	64"	64"
Electrical Requirements:			
Voltage/Phase	120V/1	120V/1	120V/1
Amperage	10.5 AMPS	10.5 AMPS	10.5 AMPS
Horsepower	1/3	1/3	1/3
Approximate Shipping Weight:			
without options	480 lbs.	495 lbs.	535 lbs.

